

**U.S. Automation, Inc.**

**REGISTRATION FANOUT—BUSTLE WHEEL**

**RBW-1000**

**Air-Assisted Register Bustle Wheel System**

**U.S. Automation, Inc.**  
21360 Gateway Court  
Brookfield, WI 53045  
USA

PH: (262) 717-0477  
Email: Sales@USAutoCorp.com

---

***Bustle Wheels for Curing Fan-Out and Marking Problems***

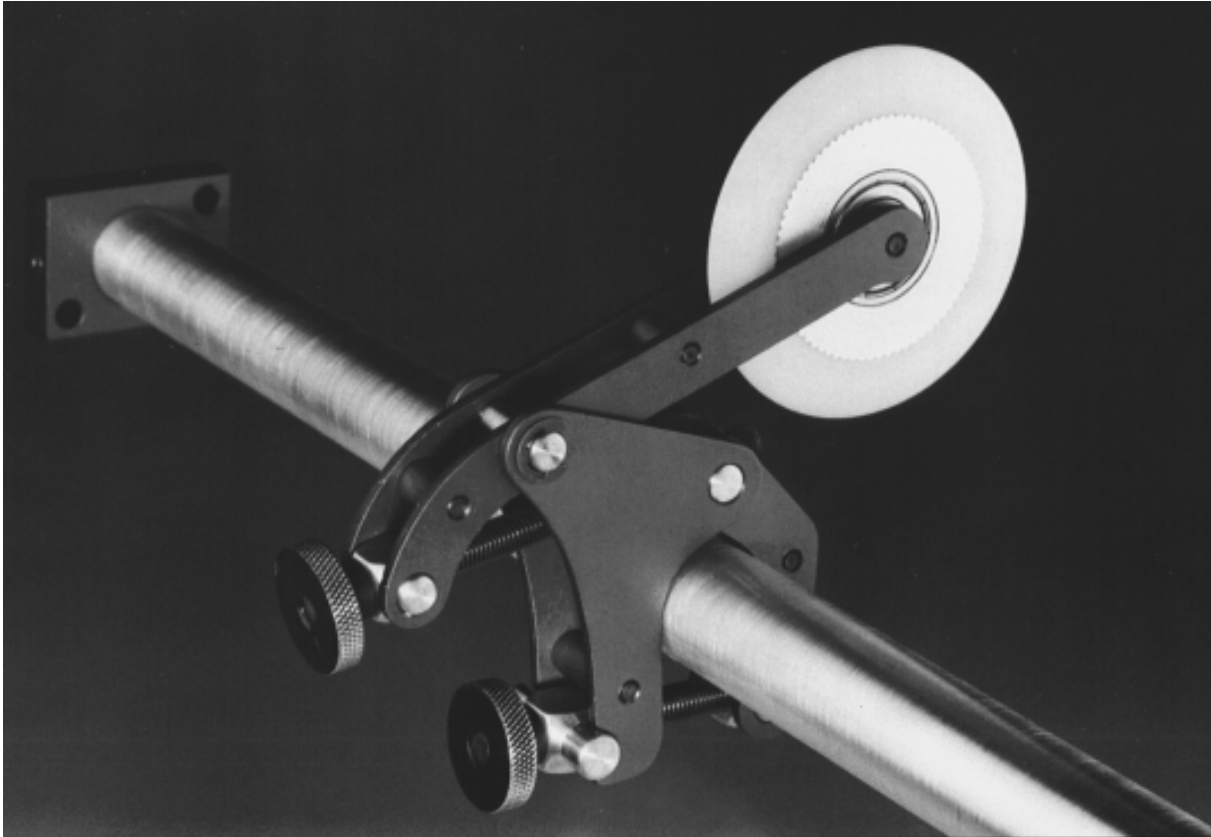

- Cures fan-out on multi-color print runs where register fit is critical
- Reduces waste while improving quality and production
- Delrin® bustle wheel with precision bearings for high-speed use
- Anodized aluminum components for corrosion resistance
- Precision machined trunnions and threaded pivots for ease of adjustment
- Easy adjustment without the use of tools that could fall into the press

## -System Configuration-

### RBW-1000 Bustle Wheel Assembly

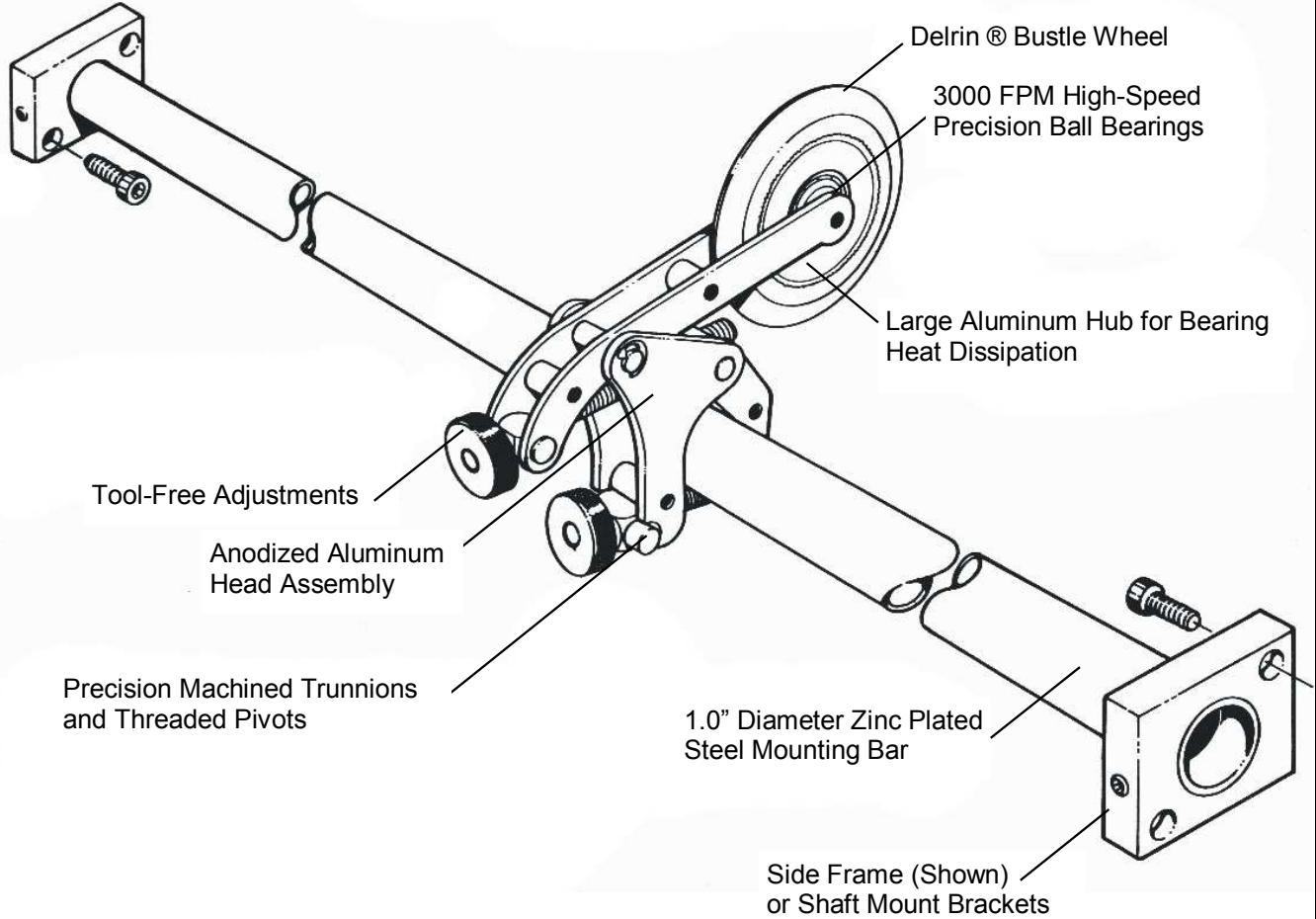

#### SPECIFICATIONS

General:	
Mounting:	Side Frame or Shaft Mount Brackets
Press Speeds:	Up to 3000 Feet Per Minute
Construction:	
Bustle Wheel:	Delrin®
Head Assembly:	Anodized Aluminum
Bearings:	Aluminum Hub with High-Speed Ball Bearings
Mounting Bar:	Zinc Plated Steel Tube
Other:	Precision Machined Trunnions and Pivots

#### RBW-1000 ASSEMBLY INCLUDES:

- Head Assembly (Number Varies with Press Width)
- 1.0" Diameter Mounting Bar
- Mounting Bar Hardware

Delrin® is a registered trademark of DuPont