

NERLITE® BAR LIGHT

Compact Lighting Solution



Omron Microscan's wide range of NERLITE products can illuminate any part or mark for successful machine vision and auto ID applications.

Bar lights are an economical source of uniform incident lighting in a low profile, compact shape. Useful for both dark field (creating shadows and specular reflection) and bright field lighting, adjustments to working distance and angle provide good image contrast on diffused surfaces. Models for continuous or strobe operation support static or high speed applications.

Bar Light: At a Glance

- Economical, general purpose design
- Provides even illumination in a concentrated area
- Address a broad range of applications via light positioning in bright field or dark field
- Variety of colors and sizes for both continuous and strobe operation
- Sturdy housings combined with LEDs rated at up to 50,000 hours
- Diffuser accessory included

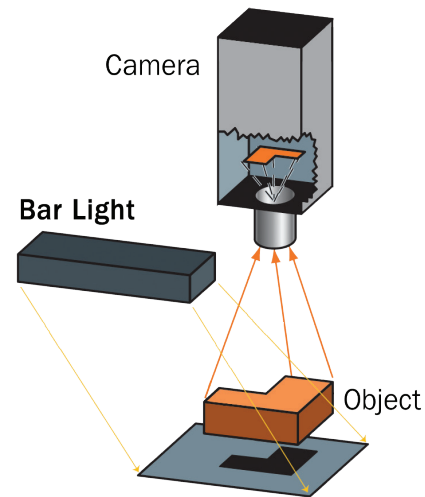

Illumination Example:

Object

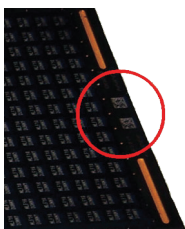

Resulting Image



Circuit board: Image captured shows high contrast Data Matrix symbols.

Application Examples

- Locate or measure outside dimensions
- Illuminate flat, diffused surfaces
- Product defect inspection
- Label placement verification
- Non-diffuse incident (front) lighting
- Dark field or bright field lighting

For more information on this product, visit www.microscan.com.

NERLITE® BAR LIGHT SPECIFICATIONS AND OPTIONS

LA 50

DESCRIPTION	nm/K	CONT. CURRENT	mcd/cm ²	
			DIFFUSE	NON-DIFFUSE
LA-50-1, Red Continuous	660 nm	23 mA	2980	5520
LA-50-1, White Continuous	6500 K	40 mA	3348	6200

Active Area: 2" x 0.35" (51 mm x 8.9 mm) **Weight:** 3 oz. (78 g)
Dimensions: H 0.75" (19.1 mm) x W 2.21" (56.1 mm) x D 0.6" (15.2 mm)

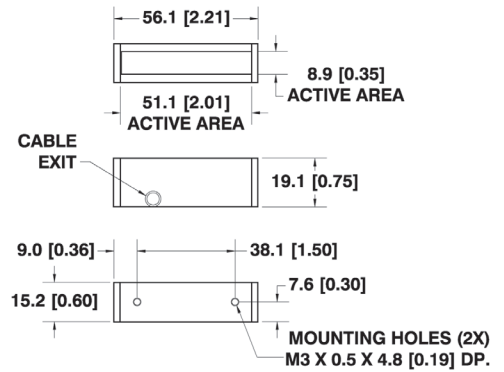

LA 150

DESCRIPTION	nm/K	CONT. CURRENT	mcd/cm ²	
			DIFFUSE	NON-DIFFUSE
LA-150-1, Red Continuous	660 nm	69 mA	2484	4600
LA-150-1, White Continuous	6500 K	120 mA	3348	6200

Active Area: 6" x 0.35" (153 mm x 8.9 mm) **Weight:** 5 oz. (136 g)
Dimensions: H 0.75" (19.1 mm) x W 6.21" (157.7 mm) x D 0.6" (15.2 mm)

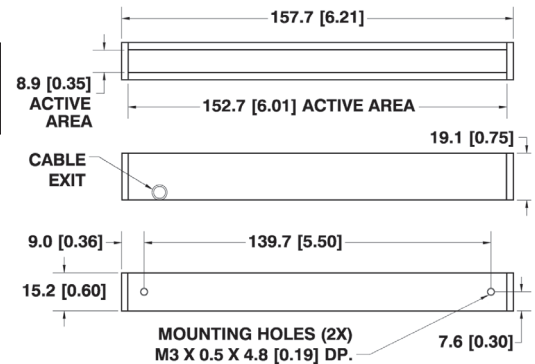

ENVIRONMENTAL

Operating Temperature: 0° to 40° C (32° to 104° F)

Storage Temperature: 0° to 50° C (32° to 122° F)

Humidity: up to 95% (non-condensing)

LIGHTING PARAMETERS

Active Area Defined: Area of light output from the illuminator.

LIGHT SOURCE

Type: High output LEDs

Light Output: Millicandelas per square centimeter (mcd/cm²)

Expected Life: 50,000 hours (Red LEDs)

Expected Life: 10,000 hours (White LEDs)

Eye Safety: EN 60825-1: Class 1 (Red, White LEDs)

CONNECTOR

Type: 15 ft. (4.5 m) integrated cable with flying leads

ELECTRICAL

Power (Continuous Models): 24 VDC +/- 1%

Power (Strobe Models): 1 ms max. pulse width, 6% max duty cycle, use of NERLITE NL-200 Series Lighting Controller is required.

CE COMPLIANT

ISO CERTIFICATION

Certified ISO 9001:2008 Quality Management System

©2018 Omron Microscan Systems, Inc. SP068F-EN-0518

Omron Microscan Applications Engineering is available to assist with evaluations. Results may vary depending on symbol quality.

Warranty—For current warranty information on this product, please visit www.microscan.com/warranty.

OMRON
MICROSCAN

Omron Microscan Systems Inc.

Tel 425 226 5700 / 800 251 7711

Fax 425 226 8250

Omron Microscan Europe

Tel 31 172 423360 / Fax 31 172 423366

Omron Microscan Asia Pacific

Tel 65 6846 1214 / Fax 65 6846 4641

www.microscan.com

Product Information: info@microscan.com

Technical Support: helpdesk@microscan.com