

PANELSCAN™

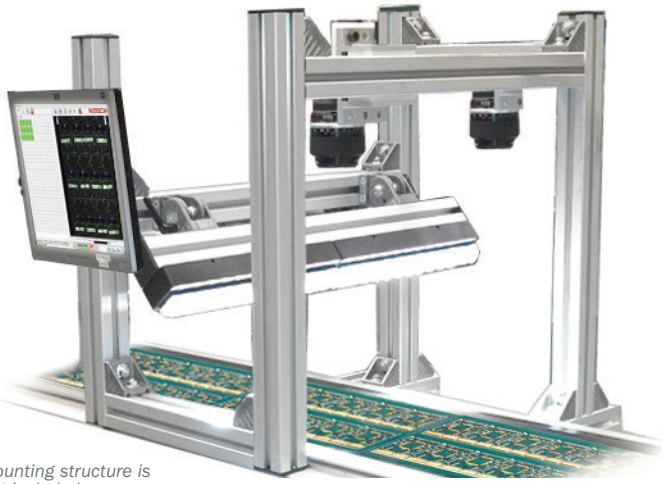

*Mounting structure is not included.

Multi-Array PCB Traceability System

PanelScan is a user-friendly and easily integrated traceability solution for capturing barcode data from multi-array PCBs at the front-end or mid-stream on any SMT line. This integrated system replaces error-prone manual scanning with a solution that allows for in-motion reading and keeps production lines moving.

The PanelScan system is the ideal traceability and inspection solution for any high mix, low volume electronics manufacturer.

PanelScan: At a Glance

- Inline decoding and verification of 1D/2D codes
- Scalable to Visionscape for additional inspection tasks
- Available in both Standard and Wide versions for flexible implementation
- Solution includes software, camera, lens, light, trigger and cables:

PanelScan Software: User-friendly interface to set up and run jobs

GigE Camera: Up to two GigE line scan cameras and telemetric lenses

NERLITE Smart Series Light: Up to two lights with focused lens and brightest LEDs in their class

For more information on this product, visit www.microscan.com.

Large Area Imaging

PanelScan is a cost-effective large area imaging system designed to read the entire length and width of any printed circuit board array.

Remote Configuration

After setup, line changes are easily managed within the software so that updates can be configured remotely or through automation. Product mix and barcode location changes no longer require lengthy line shut-downs to reposition, reconfigure, and test barcode readers.

Easily Integrated

PanelScan is a packaged solution that can be integrated into almost any production environment. Built-in software application utilities allow integration into an existing Manufacturing Execution System (MES).

Intuitive User Interface

The innovative PanelScan interface is exceptionally easy to use. Line operators can quickly train and recall jobs to make sure production is always running.

Scalable Software

Easily upgrade to full functionality of Visionscape® software to access value-added inspection tasks such as absence/presence, measurement, and OCR/OCV.

Application Examples

- Contract manufacturers
- Automotive electronics
- Medical electronics
- Military electronics
- Large-format PCB assemblers
- Machine builders
- MES providers
- Material handling

PanelScan: User Interface

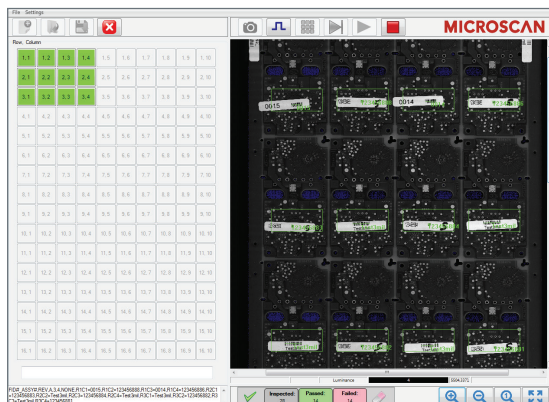

PANELSCAN™ SPECIFICATIONS AND OPTIONS

Mounting Specifications:

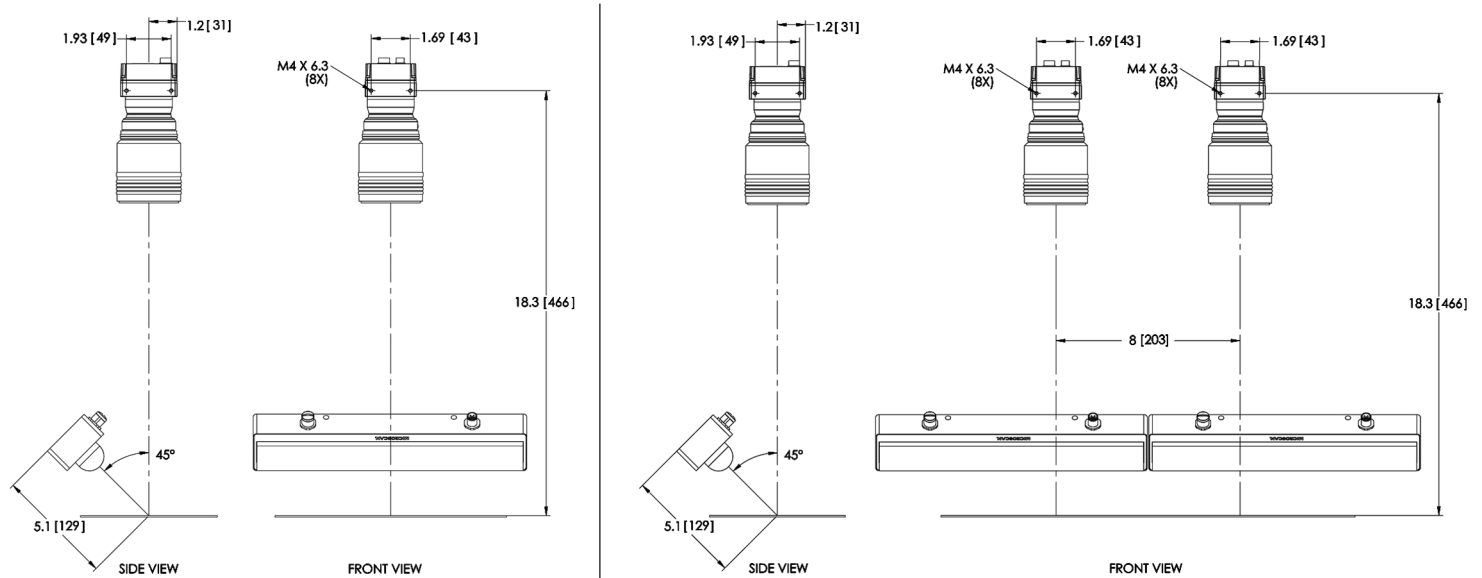

STANDARD CONFIGURATION

- One camera
- One light
- Field of view: 10" (254 mm) max. width by 24" length

WIDE CONFIGURATION

- Two cameras
- Two lights
- Field of view: 18" (457 mm) max. width by 24" length

Note: Inches [millimeters]. Nominal dimensions shown. Typical tolerances apply.

Camera Specifications:

MECHANICAL (CAMERA)

- Height:** 2.44" (62 mm)
- Width:** 2.20" (56 mm)
- Depth:** 1.42" (36 mm)
- Weight:** 8 oz. (240 g)

MECHANICAL (F-MOUNT ADAPTER)

- Height:** 1.43" (36.4 mm)
- Diameter:** 2.32" (59 mm)

MECHANICAL (LENS)

- Height:** 2.9" (74.5 mm)
- Diameter:** 2.8" (70 mm)
- Weight:** 15.5 oz. (440 g)

COMMUNICATION PROTOCOL

Interface: Gigabit Ethernet

LIGHT COLLECTION

- Sensor:** Linear CMOS, 1 by 6144 pixels
- Line Rate:** 17 kHz

ELECTRICAL

- Power:** 12–24 VDC (±5%)
- Power Consumption:** 4.5 W

DIGITAL I/O

3 in / 2 out or direct encoder input

Light Specifications:

MECHANICAL

- Height:** 2.24" (57 mm)
- Width:** 11.81" (300 mm)
- Depth:** 2.07" (52.6 mm)
- Weight:** 50.16 oz. (1422 g)

LIGHTING PARAMETERS

- Lens:** Collimating
- Temperature:** 5000 K – 8300 K
- Continuous Output:** 1813 lumens

LIGHT SOURCE

- Type:** High output LEDs
- Expected Life:** 50,000 hours
- Eye Safety:** EN 60825-1: Class 2

CONNECTOR

- Input:** M12 5-pin plug, A-code
- Output:** M12 5-pin socket, A-code

ELECTRICAL

- Power:** 20.2–28.8 VDC
- Current Draw at 24 VDC (typ.):** 750 mA
- Continuous Operation:** No additional signals required
- Continuous Operation with Dimming:** 0 VDC (LEDs off) to 3.1–3.5 VDC (LEDs on) PWM signal. < 1 mA, modulation frequency 2 KHz +/- 100 Hz. Note: LED duty cycle will equal duty cycle of dimming signal when using this mode.
- Continuous Operation with On/Off Control:** 0 VDC (LEDs off) to 3.1–3.5 VDC (LEDs on), < 1 mA

MINIMUM PC REQUIREMENTS

- Windows® 7 64-bit
- 2 GB of memory
- Two GigE NIC ports with Intel® chip set

SYMBOLGY TYPES

- 2D Symbologies:** Data Matrix (ECC 0-200), QR Code, Micro QR Code
- Stacked Symbologies:** PDF417, GS1 Databar (Composite & Stacked)
- Linear Barcodes:** Code 39, Code 128, BC 412, I 2 of 5, UPC/EAN, Pharmacode, Codabar, Code 93
- Narrow Bar Width Dimensions:**
1D = 3.3 mil (0.0033"/0.08 mm)
2D = 5 mil (0.005"/0.13 mm)

QMS CERTIFICATION

www.microscan.com/quality

©2018 Omron Microscan Systems, Inc. SP084C-EN-0518
Read Range and other performance data is determined using high quality Grade A symbols per ISO/IEC 15415 and ISO/IEC 15416 in a 25° C environment. For application-specific Read Range results, testing should be performed with symbols used in the actual application. Omron Microscan Applications Engineering is available to assist with evaluations. Results may vary depending on symbol quality. **Warranty**—For current warranty information on this product, please visit www.microscan.com/warranty.

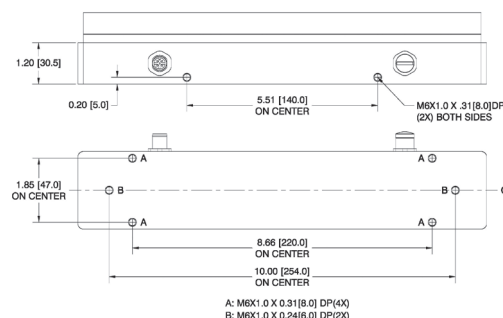
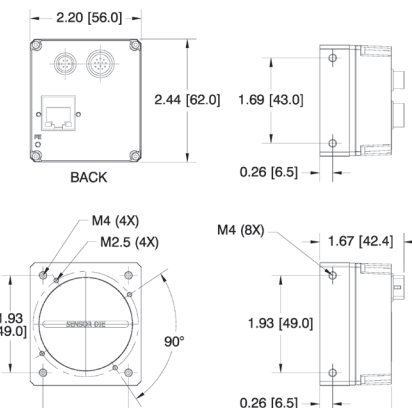

OMRON
MICROSCAN
www.microscan.com